

Dave's Exterior Products

421-DAVE(3283)

May 2009

Featuring Phenolic Resin Exterior Materials & PVC

***Superior Finishing and Durability Over Wood**

***Rot Resistant**

***Primed with Mold & Fungus Resistant Primer**

***16' Lengths (90%)**

***Low Maintenance Compared to Wood**

***Primed Spruce Boards**

***Cypress Run To Order Profiles**

Table Of Contents



DOOR & WINDOW SURROUNDS.....	2
DOOR & WINDOW SURROUNDS.....	3
EXTERIOR RESIN STRIPS.....	4
EXTERIOR START N' STOP FLUTING.....	5
EXTERIOR PLINTHS ROSETTES KEYSTONES.....	6
EXTERIOR FRIEZE & FACIA.....	7
EXTERIOR CROWN.....	8
EXTERIOR ALUMINUM.....	9
EXTERIOR ACCESSORIES.....	9
EXTERIOR WINDOW SILL.....	9
EXTERIOR MISC MOULDING.....	10
EXTERIOR RAKE.....	11
EXTERIOR SIDING.....	11
EXTERIOR DECORATIVE HEADERS.....	12
EXTERIOR RADIUS MOULDINGS.....	13
EXTERIOR RADIUS HEADERS.....	14
EXTERIOR PANELING.....	15
EXTERIOR PVC MISC MOULDINGS.....	16
EXTERIOR COLUMNS.....	17
EXTERIOR WAINSCOTT.....	18
TECHNICAL INFORMATION.....	20

132 WOODWORKERS CT., CHESAPEAKE, VA 23322
(757) 421-3283 Fax (757) 421-4252

DOOR & WINDOW SURROUNDS

3 1/4" Pebble Beach Window Trim
EXR DWPB 3 1/4
(801)

15/16" x 3 1/4"

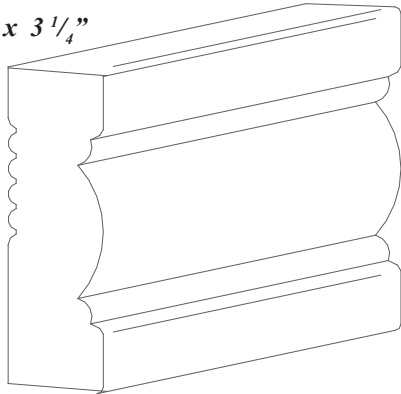

3 3/8" Traditional Adams
EXR DWTA 3-3/8
(103)

15/16" x 3 3/8"

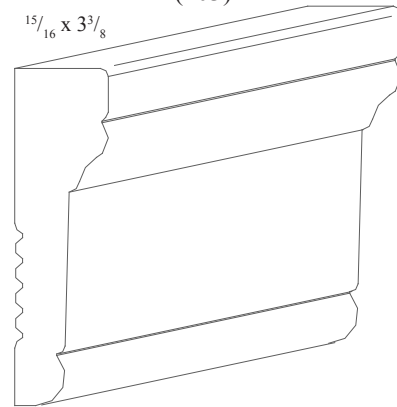

3 1/4" Fluted
EXR DWFL 3-1/4
(116)

5/8" x 3 1/4"

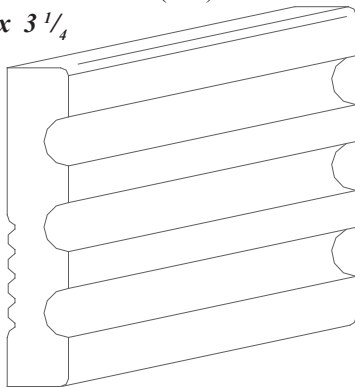

**50%
SCALE**

7" Fluted
EXR DWFL 7
(119)

5/8" x 7"

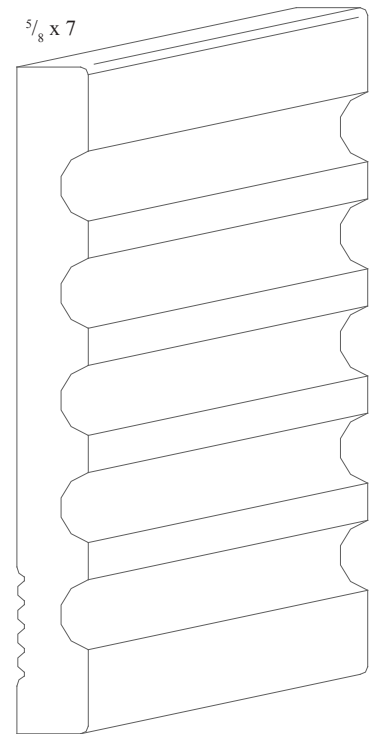

4 1/4" Fluted
EXR DWFL 4-1/4
(118)

5/8" x 4 1/4"

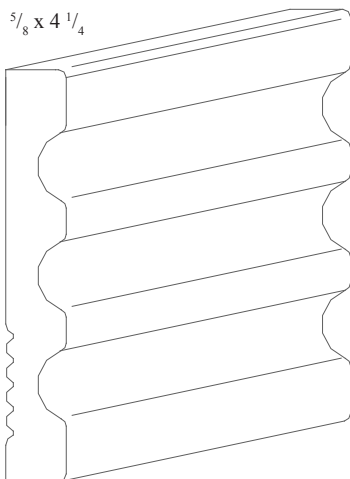

5 1/4" Fluted
EXR DWFL 5-1/4
(120)

5/8" x 5 1/4"

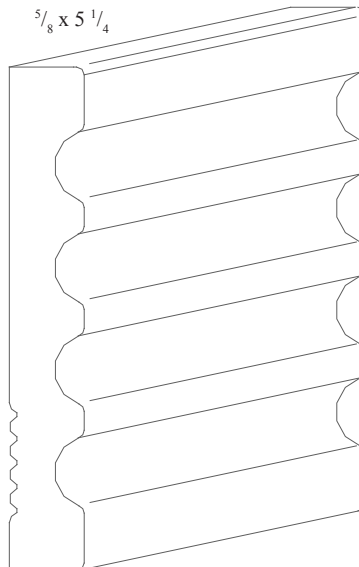

DOOR & WINDOW SURROUNDS

Window Trim

1 3/8" Softline Backband

EXR DWSL 1-3/8

EXP DWSL 1-3/8

(815)

15/16" x 1 3/8"

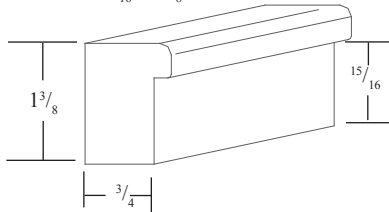

Tucker Backband

EXP BBTU 1-1/2

P.V.C. ()

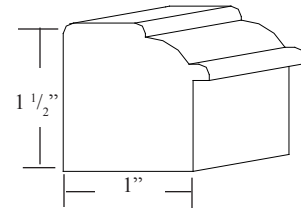

Softline Backband
Available in
Exterior Resin &
PVC

3 1/4" Beaded Window Trim

EXR DWSB 3-1/4

Stock: Primed HDF (104)

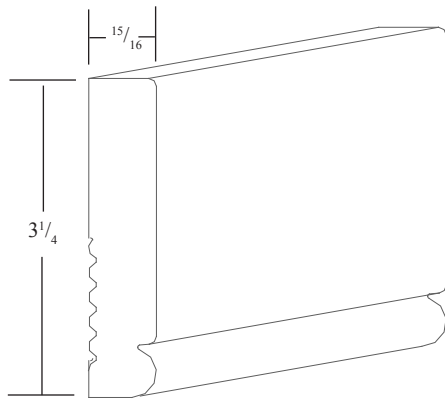

15/16" x 3 1/4"

Please Note:
Back is Textured

50%
SCALE

4 1/4" Andes Window Trim

EXR DWAN 4-1/4

(112)

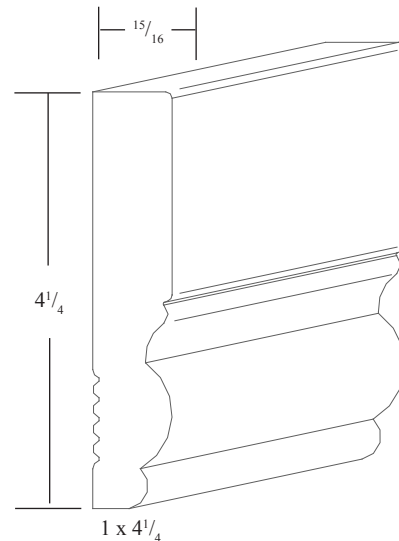

3 1/4" Colonial Window Trim

EXR DWCO 3-1/4

(101)

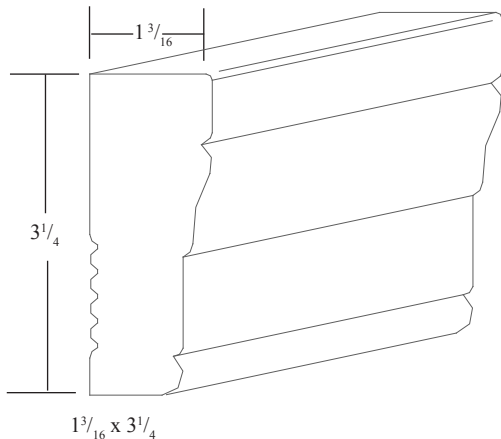

EXTERIOR RESIN STRIPS

Primed Exterior Resin

5/8" X STRIP STOCK

EXR ST5/8X 3

5/8" x 2 1/2"

EXR ST5/8X 4

5/8" x 3 1/2"

EXR ST5/8X 6

5/8" x 5 1/2"

EXR ST5/8X 8

5/8" x 7 1/4"

EXR ST5/8X 10

5/8" x 9 1/4"

EXR ST5/8X 12

5/8" x 11 1/4"

5/4" X STRIP STOCK

EXR ST5/4X 4

1" x 3 1/2"

EXR ST5/4X 6

1" x 5 1/2"

EXR ST5/4X 8

1" x 7 1/4"

EXR ST5/4X 10

1" x 9 1/4"

EXR ST5/4X 12

1" x 11 1/4"

5/8" SHEET STOCK

EXR SS5/8X 4 X 8

4' x 8'-Unfinished

EXR SS5/8X 4 X 16

4' x 16'-Unfinished

5/4" SHEET STOCK

EXR SS5/4X 4 X 8

4' x 8'-Unfinished

EXR SS5/4X 4 X 16

4' x 16'-Unfinished

Exterior Primed Spruce

EXS ST1X 4

1' x 4'-Unfinished

EXTERIOR PVC STRIPS

PVC Exterior Strips

$\frac{3}{4}$ " X STRIP STOCK

EXP ST3/4X 4

EXP ST3/4X 6

EXP ST3/4X 12

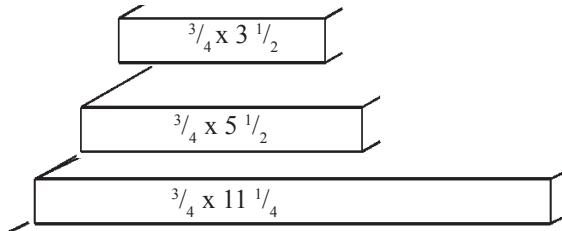

$\frac{5}{4}$ " X STRIP STOCK

EXP ST5/4X 4

EXP ST5/4X 6

EXP ST5/4X 12

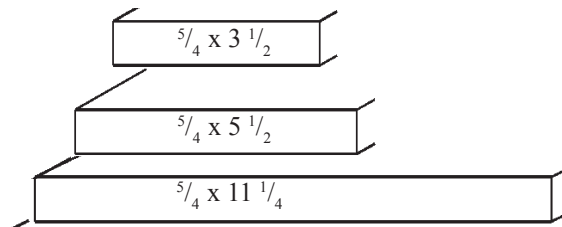

EXTERIOR START N' STOP FLUTING

5/8 x 3 1/4"

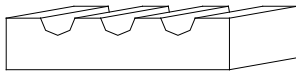

EXR MCSSFL3-1/4

5/8 x 4 1/4"

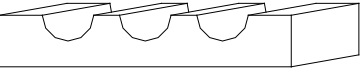

EXR MCSSFL4-1/4

5/8 x 5 1/4"

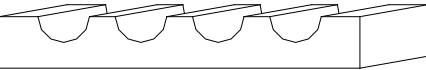

EXR MCSSFL5-1/4

5/8 x 7"

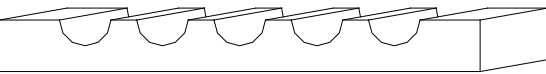

EXR MCSSFL7

5/8 x 9"



EXR MCSSFL9

5/8 x 11"



EXR MCSSFL11

IF FLUTED PATTERNS ARE USED FOR BRICK MOULD - BACKERS MUST BE APPLIED

Custom Start N' Stop Fluting

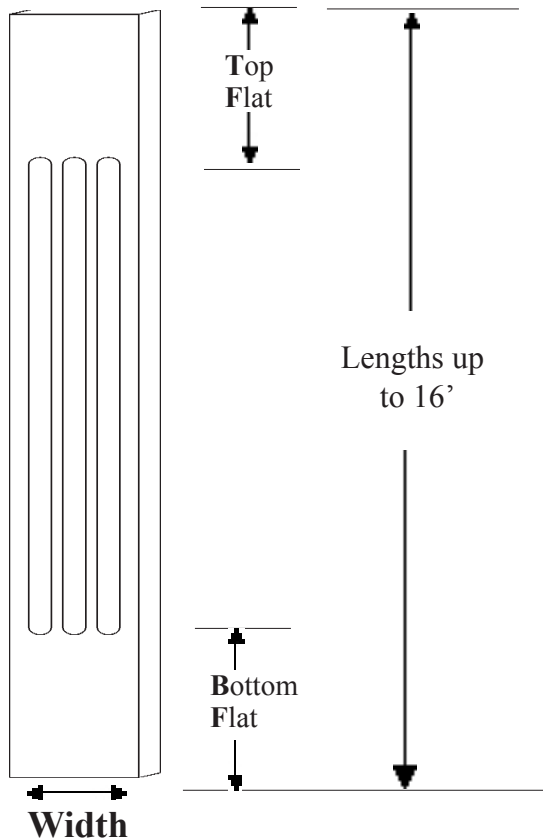

ORDER INFORMATION

- 1) Top Flat
- 2) Bottom Flat
- 3) Width
- 4) Overall Length

CAN BE MANUFACTURED INTO COLUMNS - SEE LOCK MITRE

EXTERIOR PLINTHS ROSETTES KEYSTONES

Williamsburg Plinth

EXR MCPLWB (size)

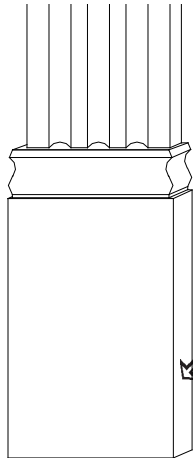

3 ³/₄ wide = 7" tall
 4 ³/₄ wide = 8" tall
 5 ³/₄ wide = 9" tall
 7 ¹/₂ wide = 10" tall

1" Thick

Raised Panel Capped Keystone

EXR MCKERC (size)

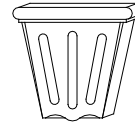

1" Thick

4 ⁵/₈ used with 3 ¹/₄ casing
 5 ⁵/₈ used with 4 ¹/₄ casing
 6 ⁵/₈ used with 5 ¹/₄ casing
 8 ⁵/₈ used with 7 ¹/₄ casing

Colonial Rosettes

EXR MCRO (size)

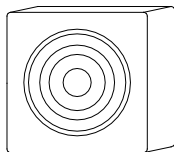

1" Thick

3 ³/₄ wide
 4 ³/₄ wide
 5 ³/₄ wide
 7 ¹/₂ wide

Plain Rosettes

EXR MCROPL (size)

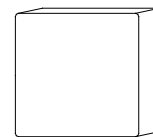

1" Thick

3 ³/₄ wide
 4 ³/₄ wide
 5 ³/₄ wide
 7 ¹/₂ wide

CAUTION-
KEYS, ROSETTES & CROWN KEYS ARE
STANDARD 1" THICK-
SET UP FOR USE WITH FLUTED PATTERNS-
THICKER MATERIALS SUCH AS
WINDOW MOULDS & BRICK MOULDIS
REQUIRE THICKER MATERIAL

EXTERIOR FRIEZE & FACIA

SINGLE BEAD
EXR FFSB 7-1/4

(807)

(Available in 5/8" x 5 1/4")

5/8" & 7 1/4"

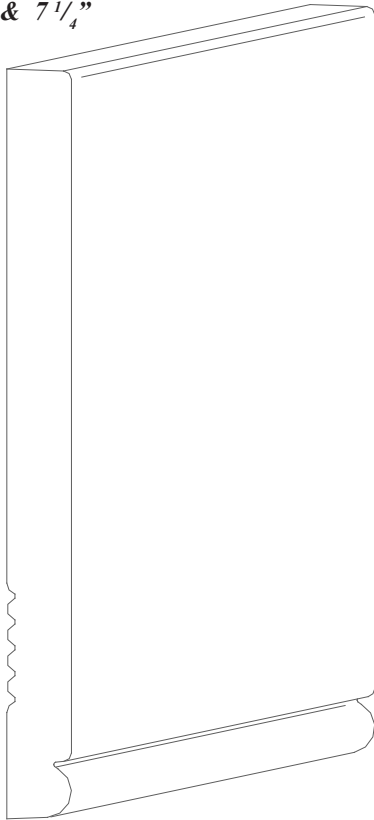

FRENCH COUNTRY
EXR FFFC 7-1/4

(808)

5/8" & 7 1/4"

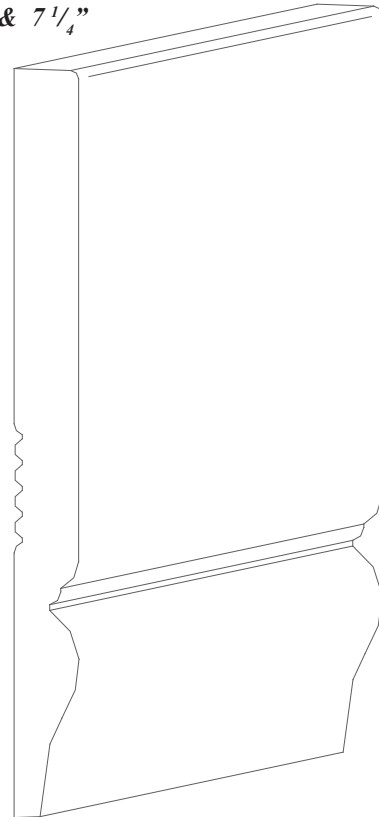

50%
SCALE

CASCADE
EXR FFCS 3-1/4
(115)

5/8" & 3 1/4"

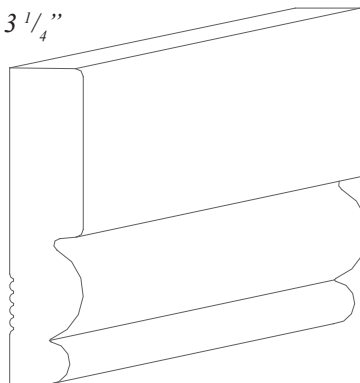

EXTERIOR CROWN

50% SCALE

1 5/8" Bed
EXR CRBE 1-5/8
(401)

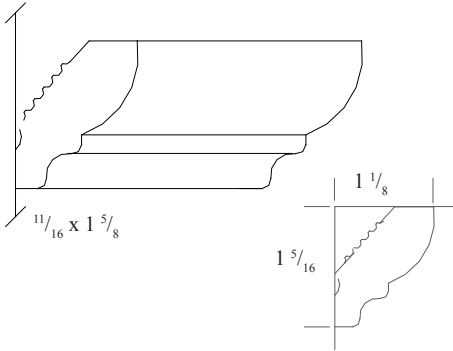

2 1/2" Capitol Crown
EXR CRCA 2-1/2
(403)

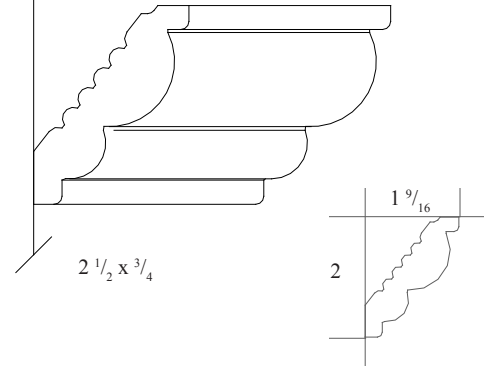

3 1/4" Colonial Crown
EXR CRCO 3-1/4
(405)

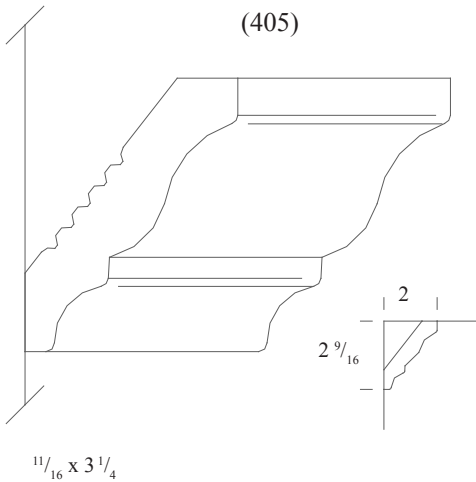

5 1/4" Colonial Crown
EXR CRCO 5-1/4
(406)

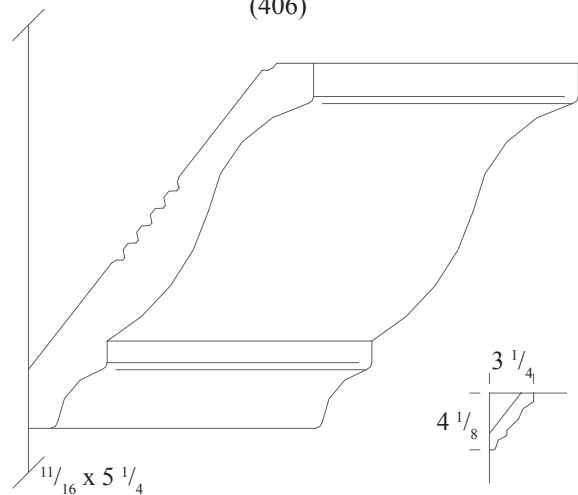

EXTERIOR CROWN

3 1/4" Cove Crown
 EXR CRCV 3-1/4
 (402)

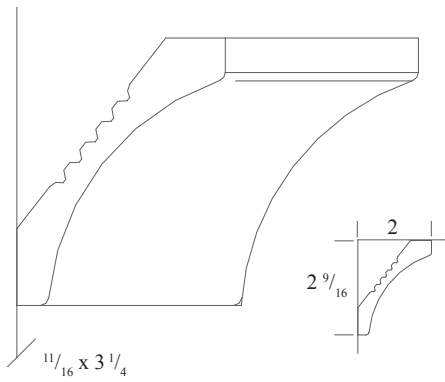

5 1/4" Cove Crown
 EXR CRCV 5-1/4
 (409)

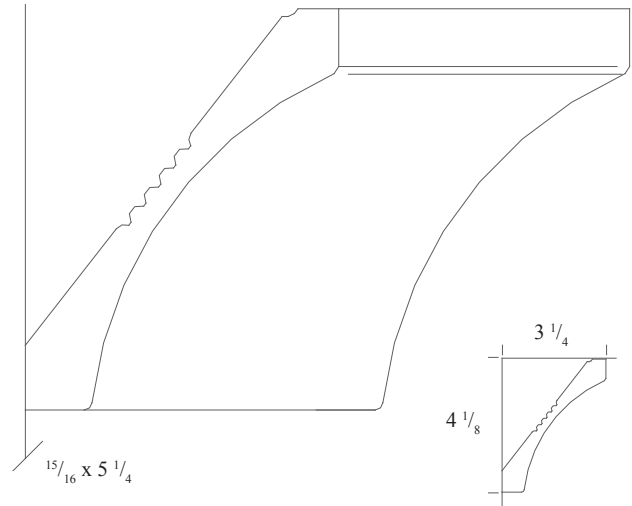

50% SCALE

5 1/4" Carawan Crown
 EXR CRCR 5-1/4
 (420)

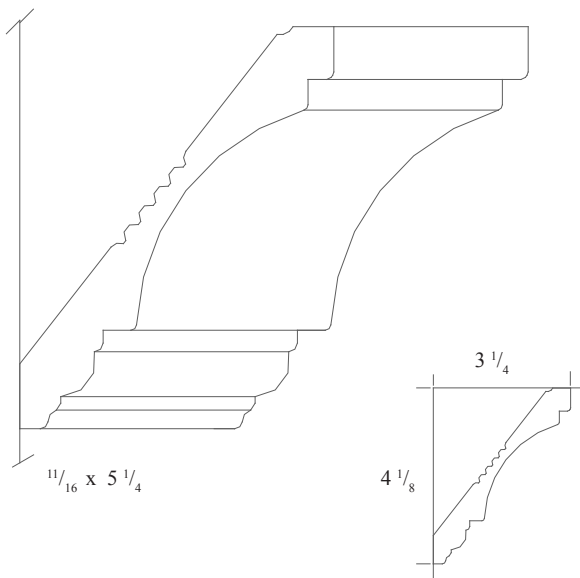

7" Carawan Crown
 EXR CRCR 7
 (411)

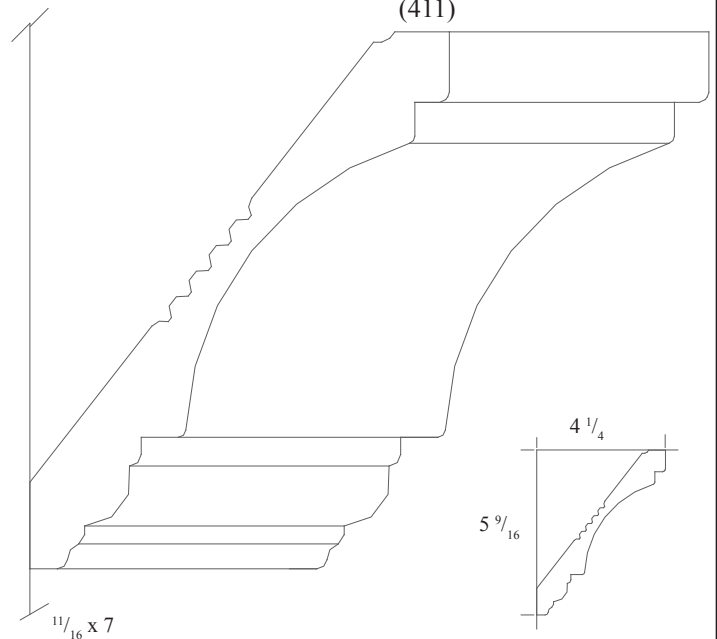

EXTERIOR ALUMINUM / VINYL

EXA MCDRIP 6
ExtAluminum DripCap 6"



EXA MCSOFVENT
ExtVinyl Sofvent



EXTERIOR ACCESSORIES

EXR ACCO SIZE
EXT FS Corbels



EXR ACDB SIZE
EXT FS Dentil Block



EXTERIOR WINDOW SILL

50% SCALE

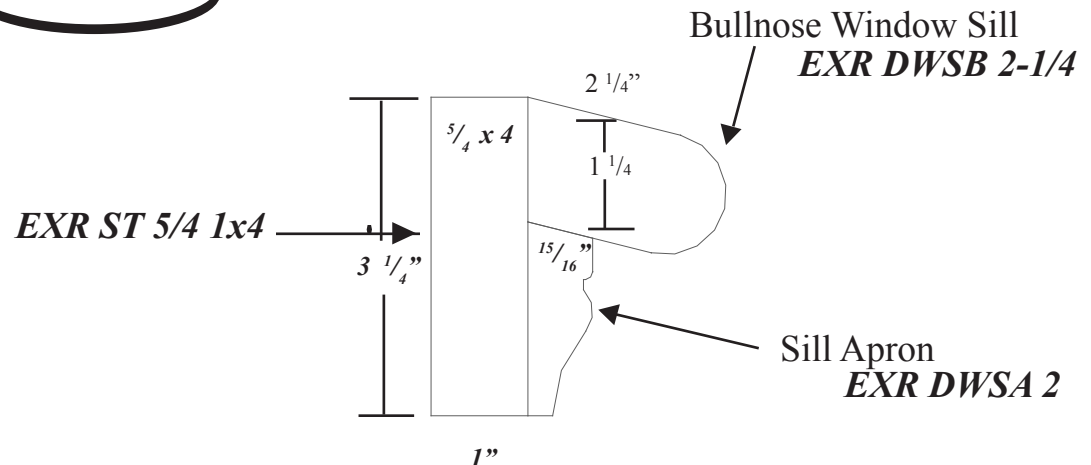

EXTERIOR MISC MOULDING

EXR ACCO SIZE

EXT FS (Component A) Beaded OC 4-1/2

EXR MMIC

EXT FS Inside Corner

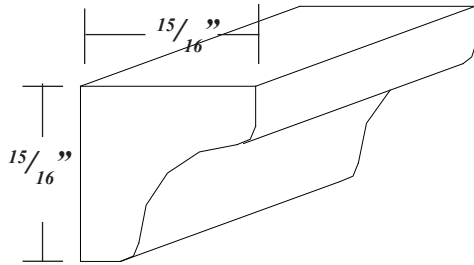

EXR MMNRT 1 3/8

Tempo NECK

(706)

$9/16 \times 1 3/8$

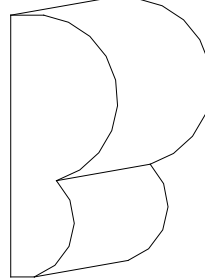

BB Edge

EXR MMBEDGE

(707)

$7/8 \times 1 9/16$

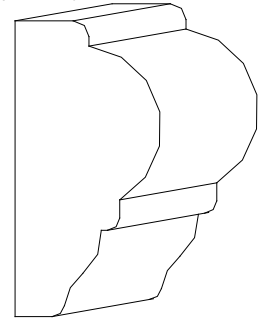

**100%
SCALE**

EXR MMPMHA

EXT FS Hampton Panel Mould

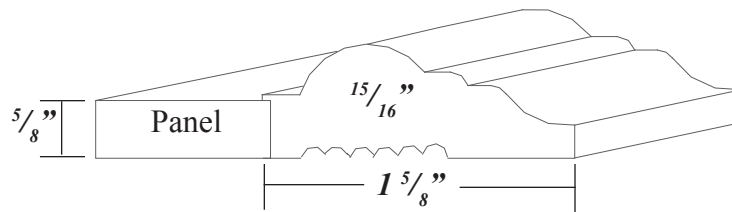

**50%
SCALE**

EXR MMLS 7-1/4

EXT FS Lap Siding

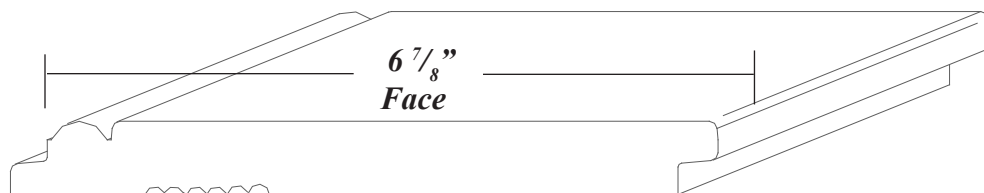

EXTERIOR MISC MOULDING

100%
SCALE

Stafford Cap
EXR
(216)

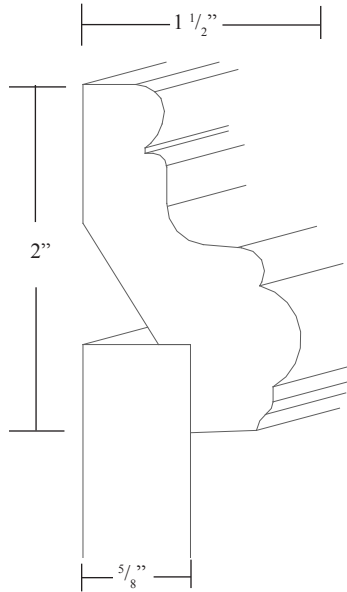

5/4" Corner Trim
EXR MMOC 4-1/2
(803)(Component A)
EXR ST5/4 x 4
(Component B)

50% SCALE

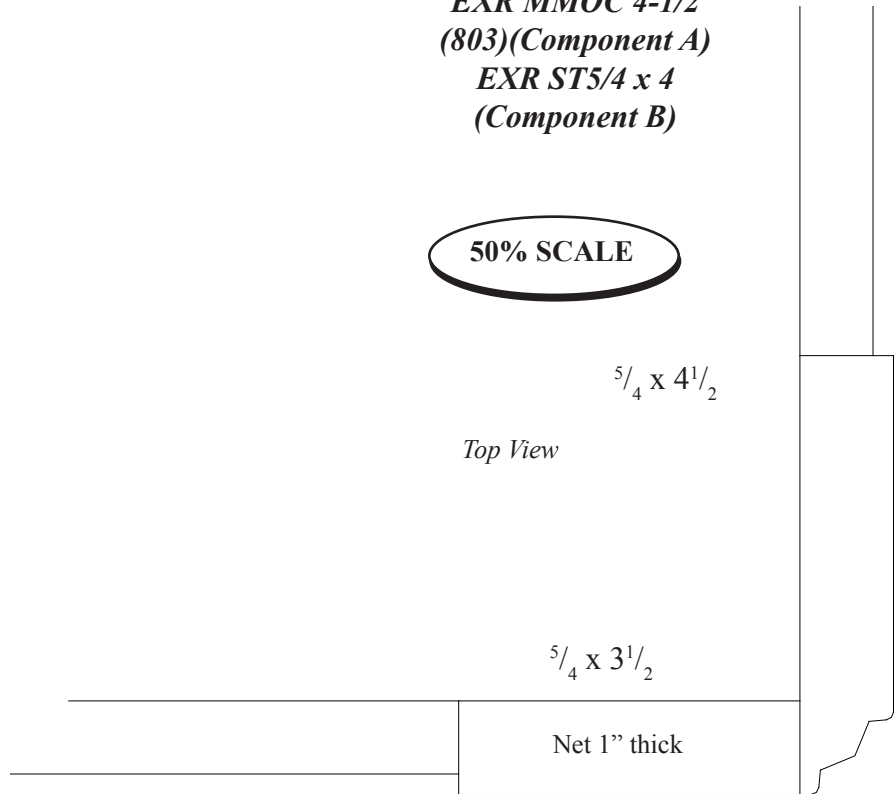

EXTERIOR RAKE

Product images coming soon!

EXTERIOR SIDING

Product images coming soon!

EXTERIOR DECORATIVE HEADERS

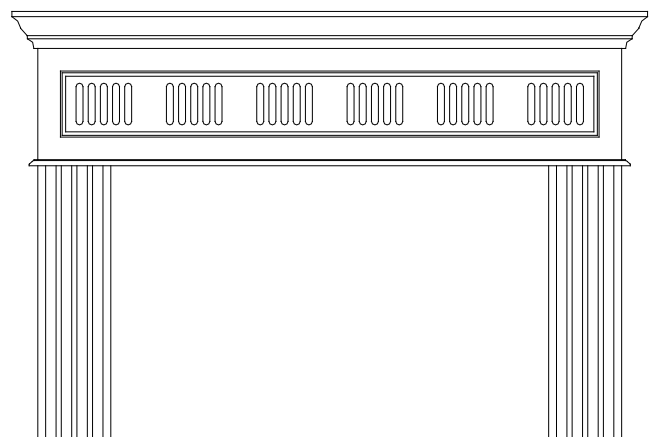
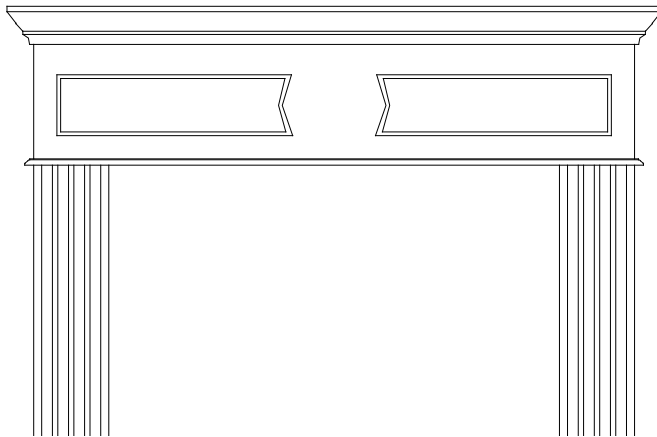
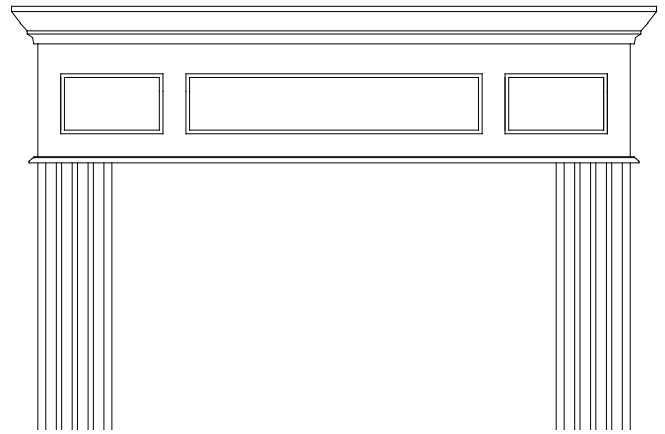
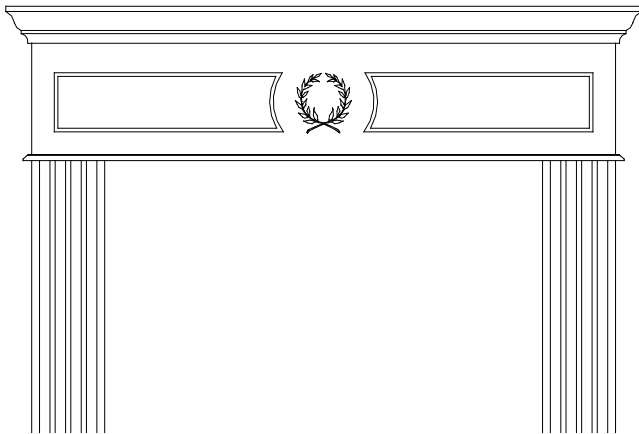

- Part Number -

EXR HD

Part Numbers in process!

EXTERIOR RADIUS HEADERS

Product images coming soon!

EXTERIOR RADIUS MOULDINGS

HALF ROUND - EXR RH

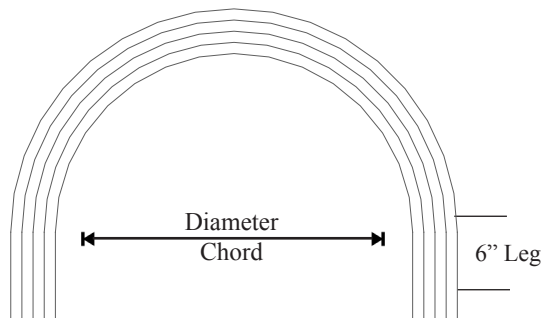

Note 1 - Half Round info required to produce is the diameter. The standard is 1/4" reveal around jamb (1/2" overall larger than diameter).

Note 2 - Half Round and other radius moulding may be produced in more than one segment. If one piece construction is required it must be specified at point of order

QUARTER ROUND -

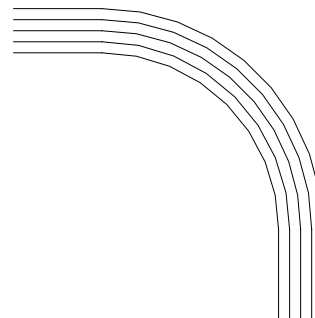

Note 1 - Quarter Round required to produce is the radius. The standard is 1/4" reveal around jamb. (Priced by the radius)

EYEBROW - EXR RI

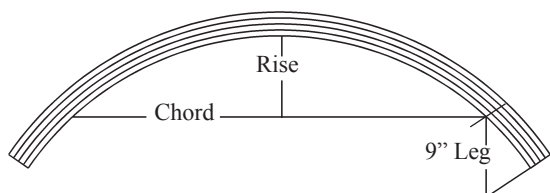

Note 1 - Eyebrow info required to produce is the Chord and Rise. The standard is 1/4" reveal around jamb

Note 2 - Eyebrows and other radius moulding may be produced in more than one segment. If one piece construction is required it must be specified at point of order

ELLIPSE/OVAL - RXR RE

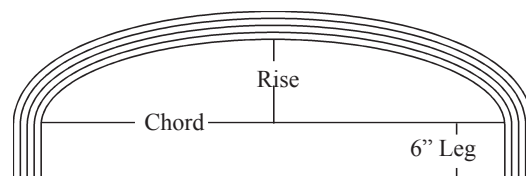

Note 1 - The Ellipse/Oval are produced from the Chord and Rise. The standard is 1/4" reveal around jamb (1/2" overall larger than Chord)

Note 2 - Ellipses and other radius moulding may be produced in more than one segment. If one piece construction is required it must be specified at point of order.

Note 3 - For Ellipse and Ovals that are used on non-Andersedn windows a tracing or pattern is required.

- Part Number Structure -

EXR (# of pieces) (thickness) (size of casing) (overall width)

	<u># of Pieces</u>	<u>Thickness</u>	<u>Size of Casing</u>	<u>Overall Width</u>
RE = Ellipse	1 = 1 Piece	A = 5/8" thick	3 = 3 1/4	3 - 4 = 3'- 4"
RH = Half Round		B = 1"	4 = 4 1/4	4 - 5 = 4'- 5"
RI = Eyebrow		C = 1 1/4" thick	5 = 5 1/4	5 - 6 = 5'- 6"
				6 - 7 = 6'- 7"
				7 - 8 = 7'- 8"

EXTERIOR PANELING

50% SCALE

3 1/4" Portsmouth Paneling
EXR PAPO 3 1/4

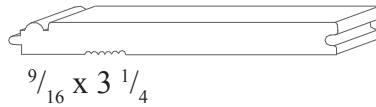

5 1/4" E Portsmouth Paneling
EXR PAPO 5 1/4

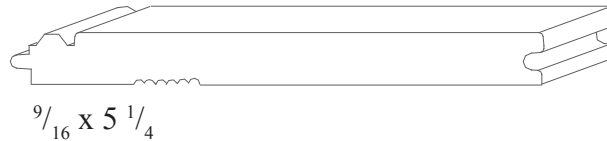

5 1/4" Beaded Paneling
EXR PABD 5 1/4

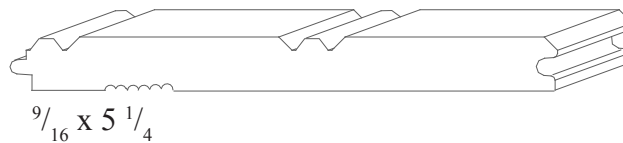

5 1/4" x 9/16" "V" Groove Paneling
EXR PAVG 5-1/4 (725)

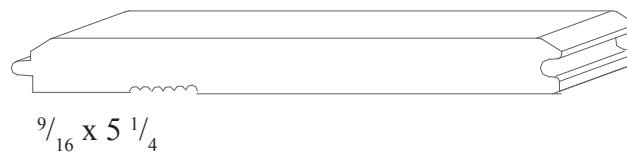

EXTERIOR PVC MISC MOULDINGS

2" Double Clam

EXP MMDC 2
(110)

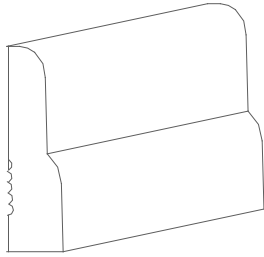

5/8 x 2

50% SCALE

2" Single Bead

EXP MMSB 2
(104)

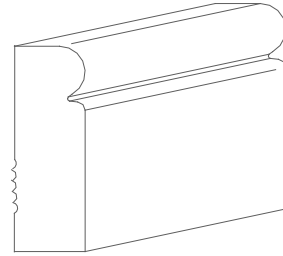

3/4 x 2

Milan Door Stop

EXP MMDSMI
(721)

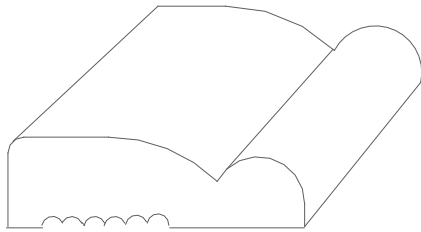

1/2 x 1 1/2

100% SCALE

Colonial Door Stop

EXPMMDSCO1-3/8
(718)

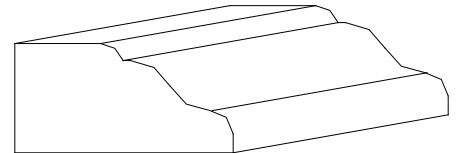

1/2 x 1 1/8

Cove Moulding

EXPMMCV-3/4
(713)

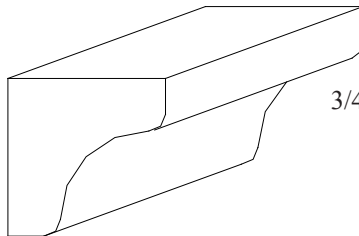

3/4 x 3/4

Premier Panel Mould

EXP MMPP
(722)

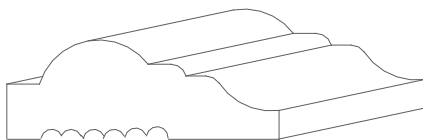

1/2 x 1 3/8

100% SCALE

Radius Neck

EXPMMRN1-1/2
(705)

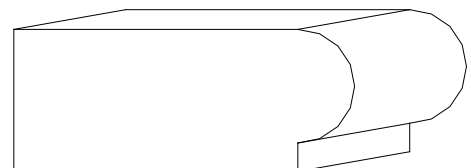

5/8 x 1 1/2

EXTERIOR COLUMNS

- Lock Mitred Square Columns -

Plain



- EXR CO4PL 6X8 (6 x 95")
- EXR CO4PL 6X8+ (6 x 96-120")
- EXR CO4PL 8X8 (8 x 95")
- EXR CO4PL 8X8+ (8 x 96-120")
- EXR CO4PL 11X8 (11 x 95")
- EXR CO4PL 11X8+ (11 x 96-120")

Raised Panel

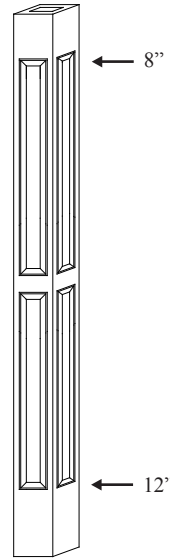

- EXR CO4RPL6X8 (6 x 95")
- EXR CO4RP 6X8+ (6 x 96-120")
- EXR CO4RP 8X8 (8 x 95")
- EXR CO4RP 8X8+ (8 x 96-120")
- EXR CO4RP 11X8 (11 x 95")
- EXR CO4RP 11X8+ (11 x 96-120")

Fluted



- EXR CO4FL 6X8 (6 x 95")
- EXR CO4FL 6X8+ (6 x 96-120")
- EXR CO4FL 8X8 (8 x 95")
- EXR CO4FL 8X8+ (8 x 96-120")
- EXR CO4FL 11X8 (11 x 95")
- EXR CO4FL 11X8+ (11 x 96-120")

Mixed Face Columns

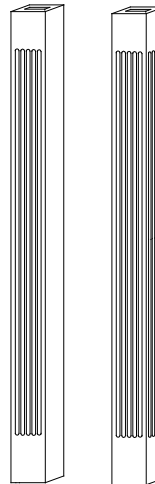

- EXR COMFA 6X8 (6 x 95")
- EXR COMFA 6X8+ (6 x 96-120")
- EXR COMFA 8X8 (8 x 95")
- EXR COMFA 8X8+ (8 x 96-120")
- EXR COMFA 11X8 (11 x 95")
- EXR COMFA 11X8+ (11 x 96-120")

* Caps and Bases are not included.

* Sold ready to Assemble

EXTERIOR WAINSCOTT

Vertical Panels

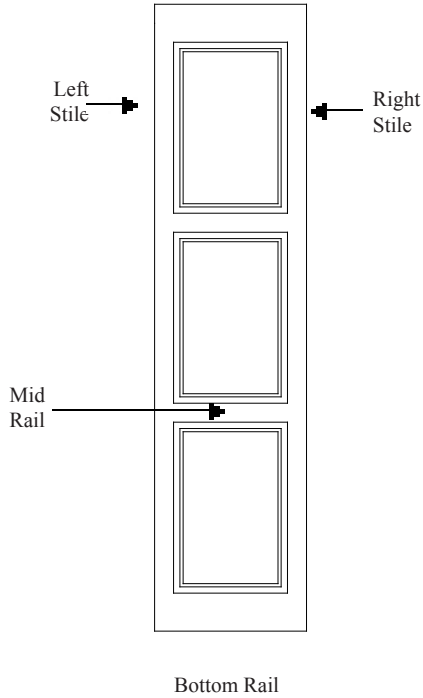

- Order Info -

- A) Width
- B) Height
- C) Top & Bottom Rail Size
- D) Mid Rail or Mid Stile Size
- E) Flat

Horizontal Panels EXR WW CUSTOM

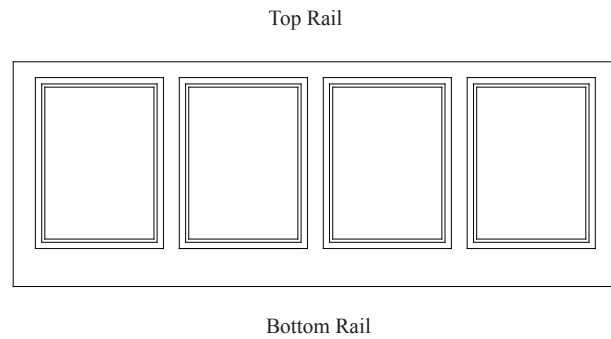

**NOTE: RAISED PANEL
COMPONENTS CAN BE
MADE FROM AZEK-(PVC)**

TECHNICAL INFORMATION

STORAGE

FiberStrate premium engineered trim should be stored flat and off the ground. Cover to protect from dirt and moisture.

INSTALLATION

FiberStrate may be used wherever Non pressure treated wood is normally used. Do not install in contact with concrete or masonry products near grade or floor (set columns & raised panel parts a min. of 1" off concrete / masonry floor level). FiberStrate should not be exposed to regular wetting by water sprinklers. FiberStrate can be nailed directly to structural members or applied over siding or other materials. When installing, nail from one end and work to the other end. Never nail from both ends to the middle. FiberStrate may be installed as fascia nailed to framing (24" o.c. max.). When applied as rake, corner, band or other uses, nail FiberStrate on each edge (16" o.c. max.). Nail through face no closer than 1/2" from edges.

FLASHING/ CAULKING

Good building practices require flashing at all horizontal material changes where water may be trapped or run behind the trim or siding, such as window and door heads or band boards separating two stories of a bulding. Caulk wherever water may run behind vertically applied trim with long-life paintable caulk.

PAINTING

All raw edges should be primed before installation / Assemble with good quality latex oil Alkyd primer. FiberStrate face and edges should be painted within 60 days after installation. Use high quality acrylic (latex preferred) or oil base exterior house paint. Follow paint manufacturer's recommendation concerning use of compatible primers, rate of spread and application procedurers. For premium finish and long life, two brush coats of unthinned paint are recommended for all exposed surfaces and edges.

- Directions from I-64 -

- Take Exit 291-B from I-64.
- Upon leaving ramp, yield all the way to the left lane to get onto the 168 Chesapeake Expressway towards "Nags Head / Manteo".
- Stay on 168 Bypass Expressway for 8.7 miles.
- Take Exit 8-B onto Hillcrest Pkwy. (Last Exit before the Toll)
- Follow exit around and go .7 miles to the dead end at traffic light.
- Turn right at the light onto Battlefield Blvd.
- Continue on Battlefield Blvd. for 2.8 miles.
- You will see the Dave's Cabinet sign on left, just before the overpass. Turn left onto Woodworkers Court. Follow to the end.

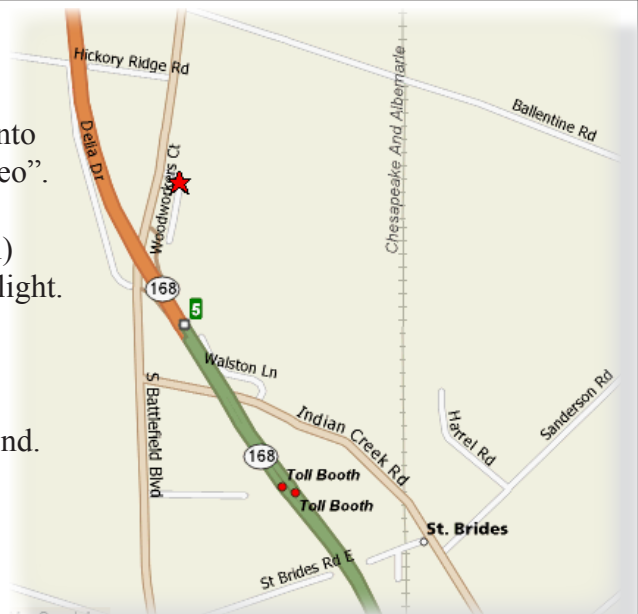

Visit us on the web. Catalogues available online.

CabinetsByDaves.com StairsByDaves.com MouldingsByDaves.com CountertopsByDaves.com

132 WOODWORKERS CT., CHESAPEAKE, VA 23322
(757) 421-3283 Fax (757) 421-4252