

Cabinet Doors and Component Parts

***Unfinished**

***Primed**

***Rigid Thermofoil**

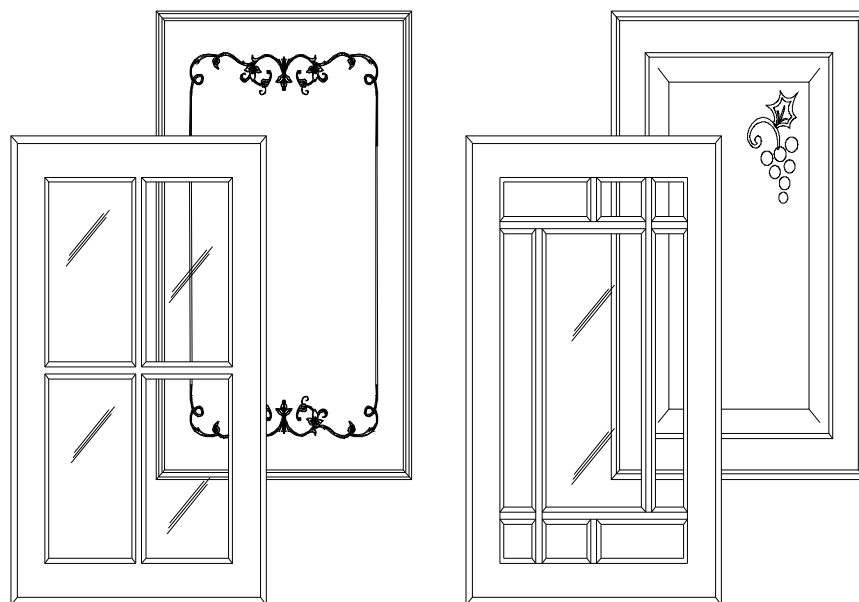
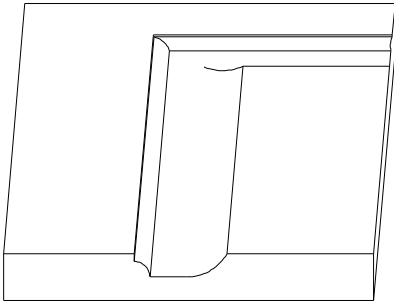

Table of Contents

Profiles / Edges / Corners.....	2	1 Lite Doors.....	8-10
Traditional Doors/Drawers.....	3-5	Mullion Doors.....	9-11
Contemporary Doors/Drawers.....	6	Product Information.....	12
Special Profile Doors/Drawers.....	7	Delivery & Ordering Information.....	13-14

132 WOODWORKERS CT., CHESAPEAKE, VA 23322
PHONE (757) 421-3283 FAX (757) 421-4252

Interior Panel Profiles



COVE

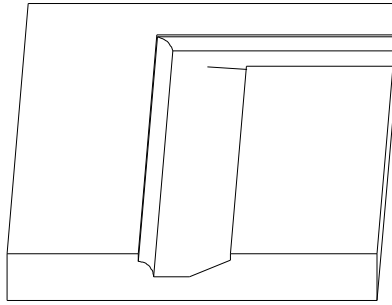

SHAKER

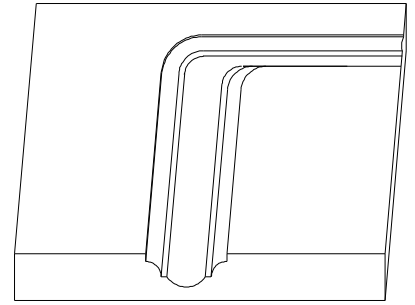

FANCY

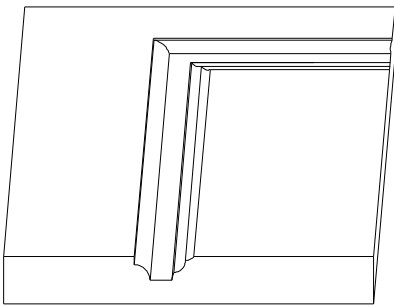

REGAL

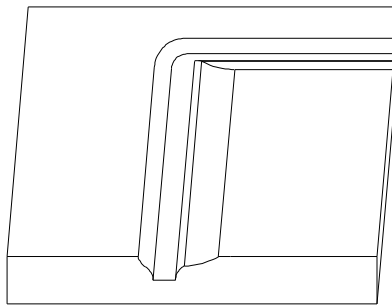

REGENCY

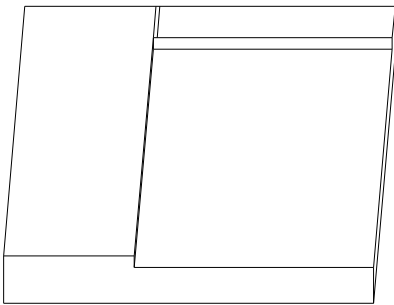

FRANKLIN

(Shown with optional Joint Accent)

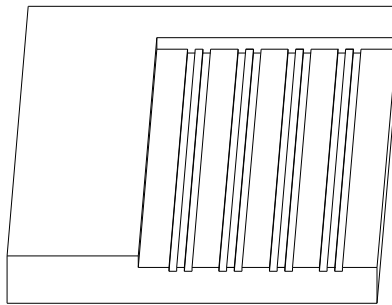

WINCHESTER

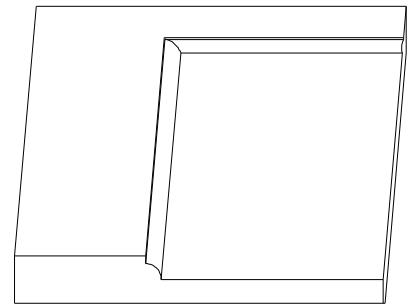

RECESSED

Door Edge Detail

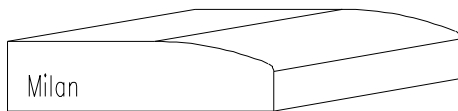

Milan

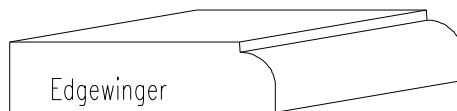

Edgewinger

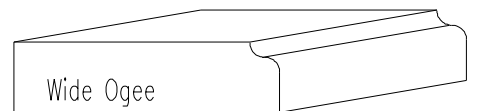

Wide Ogee

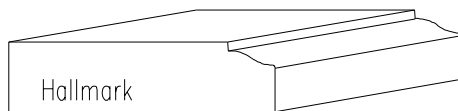

Hallmark

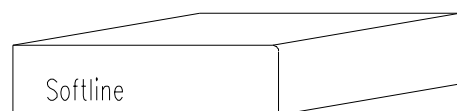

Softline

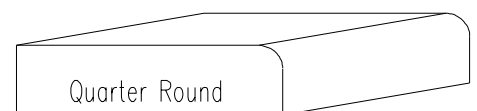

Quarter Round

TRADITIONAL DOOR SHAPES

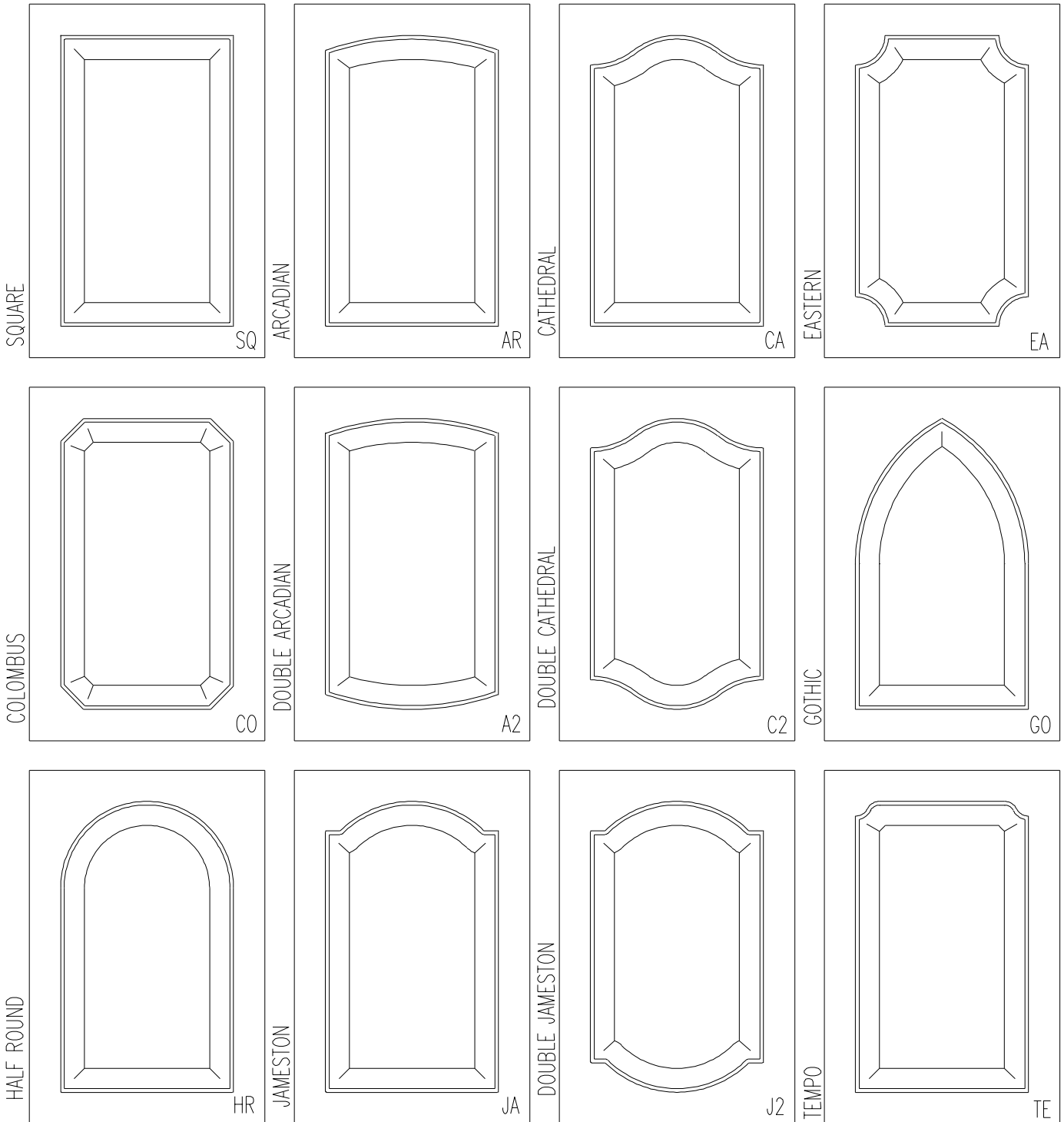

Specifications - Doors

- * Door stiles and rails are 2 3/8" wide as shown.
- * Minimum door size is 7" wide and 8" high.
- * Sample door sizes are 11" wide and 16" high.
- * All RTF and painted doors are white Melamine backed.
- * All shapes above are available in halved shapes for double doors upon request.

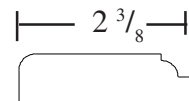

TRADITIONAL DRAWER FRONTS

Types

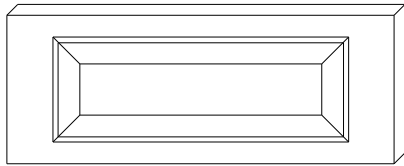

Styled

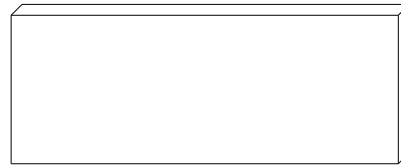

Slab

Specifications

- * Drawer Front rails are 1 1/4" wide.
- * Drawer Front stiles are 2 3/8" wide.
- * Minimum styled drawer front is 7" wide x 6 1/8" tall.
- * Caution: 7" wide drawer requires knobs, use of pulls require larger width Drawer Fronts

- * Like doors, all RTF fronts must have an edge detail. If none are specified, eased edge (1/8" round over) will be applied.

SPECIAL PROFILE DOORS/DRAWERS

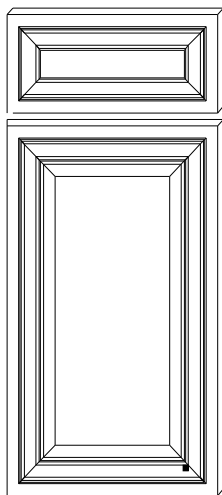

KH - Knob Hill

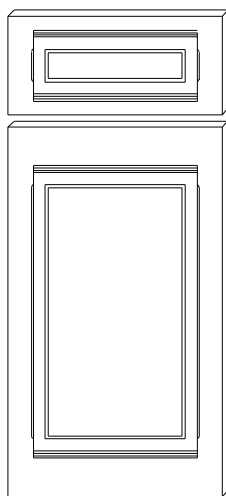

CM - Country Manor

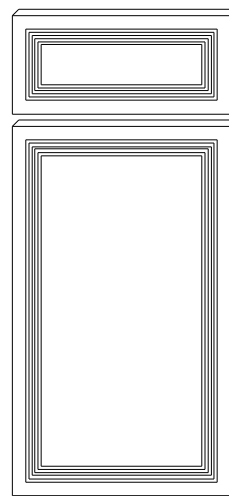

NI - Nichols

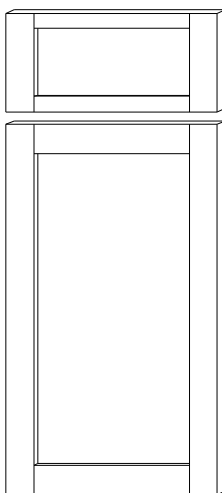

FR - Franklin

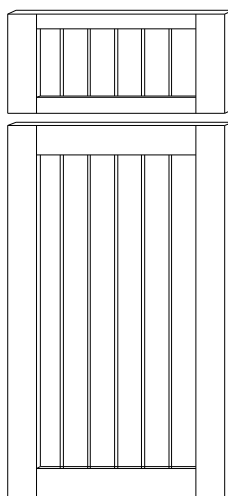

WI - Winchester

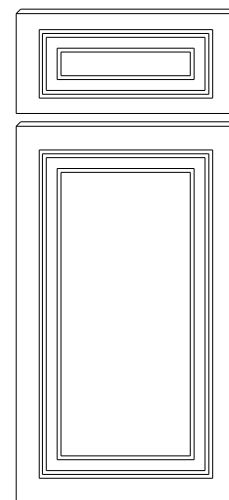

HV - Harvard

Specifications

- * Customer has choice of edge profile.
- * RTF doors require an edge profile
- * Raw HDF doors can be ordered without edge profile

1 LITE FOR TRADITIONAL DOORS

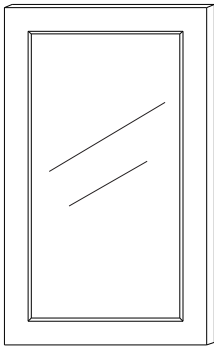

IL - One Lite

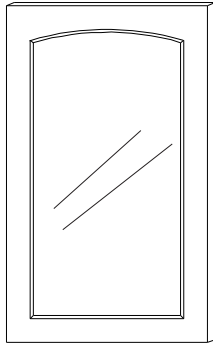

IL - One Lite

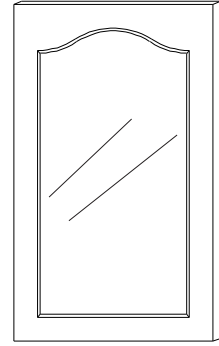

IL - One Lite

Available in all tradition shapes

STYLES

1 LITE FOR CONTEMPORARY & SPECIAL DOORS



LS - Leslie, LP - Palmer, LG - Glasgow

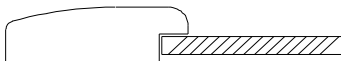

LB - Bradford

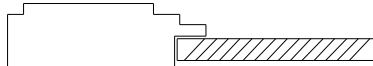

LH - Harvard

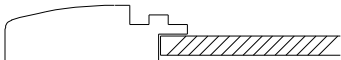

LZ - Elizabeth

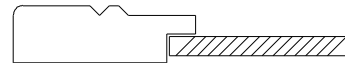

LK - Knob Hill

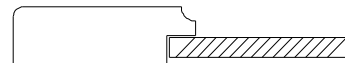

LC - Country Manor

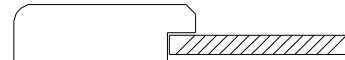

LW - Winchester



LN - Nichols



LL - Lexington

***Available only in square shape**

MULLION DOORS -- 4, 6 & LITE

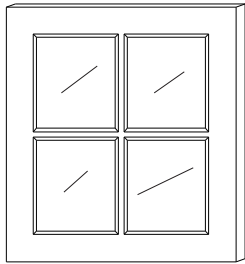

4L-4 lite Mullion
available in all door shapes

(Recommended for
doors 18" to 24" tall)

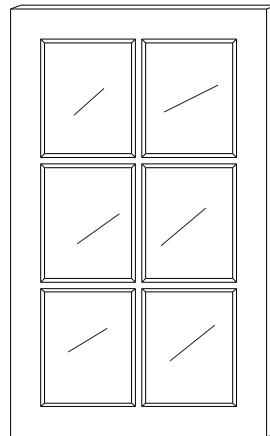

6L-6lite Mullion
available in all door shapes

(Recommended for
doors 24" to 42" tall)

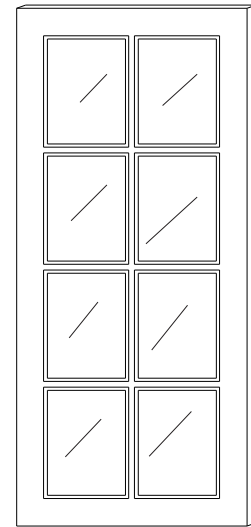

8L-8 lite Mullion
available in all door shapes

(Recommended for
doors 18" to 24" tall)

MULLION DOORS -- LEFT, RIGHT & CUSTOMS

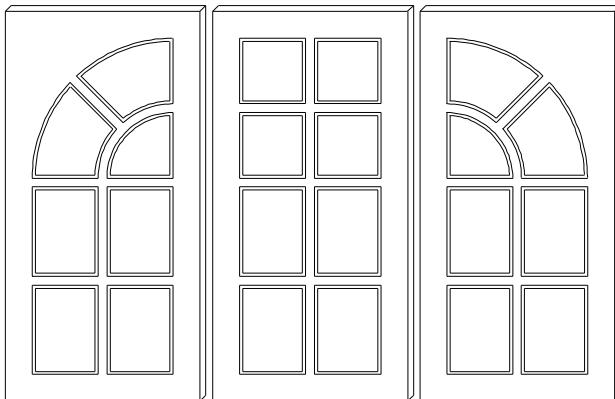

LR-left CR-ctr RR-right
Matching Mullion

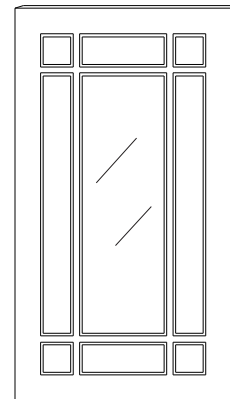

BL
Square Brighton

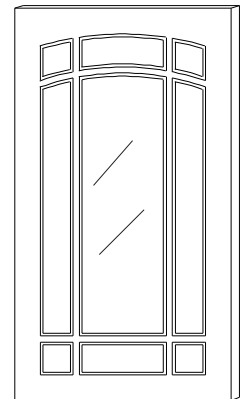

BA
Arcadia Brighton

Specifications - All Lite Doors

- * Backs are routed to accept 1pc square glass panel.
- * Mullions are 3/4" wide.
- * Standard cut yield 1/8" inside corner.
- * All RTF and painted lite doors are white Melamine backed.

END PANELS / BACKS / WAINSCOT

TW - Tall Wainscot

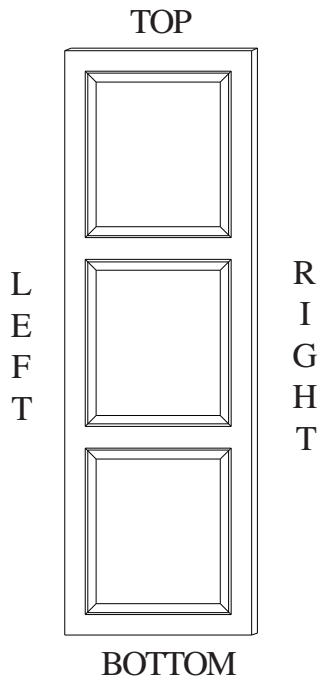

WW - Wide Wainscot

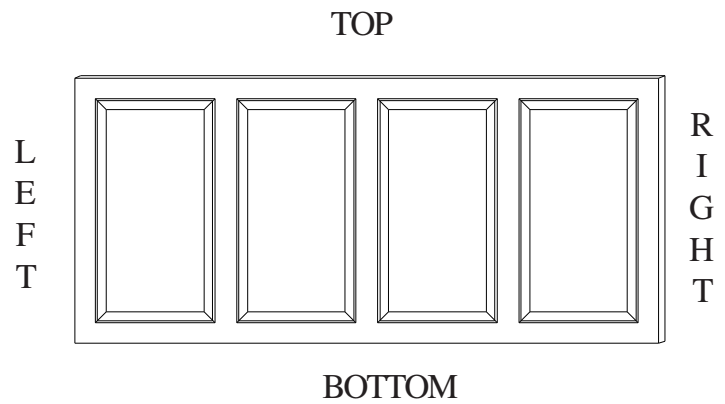

Specifications - End Panels / Backs / Wainscot

- *Edge profile not standard
- *Max size is 48" x 102"
- *4 square feet minimum size
- *Stile and Rail Standards are 3 1/4" side styles, 2 1/2" top rail, 6" bottom rail, and 2 1/2" center styles.

PRODUCT INFORMATION

HDF RAW & RIGID THERMAL FOIL RTF PRODUCT SPECIFICATIONS

Construction

- * 3/4" HDF double refined substrate wrapped with a Rigid Thermo Foil under heat and pressure. Foil thickness vary per foil.
- * On Lite and Mullion Doors the back is routed to accept a single pane glass.

Size Specifications

- * Door and drawer front sizes measured to the nearest 1/16". A difference of +/- 1/32" is acceptable.
- * Doors ordered over 26" wide or 48" high should be ordered with two equal panels.
- * Unless otherwise specified, lower panels on all multiple panel doors will be made with a square panel regardless of the door design ordered.

Vinyl Specifications

- * Machining lines may telegraph through the vinyl. If they are not visible in normal kitchen lighting at a distance of two feet or more, they will not be considered defects.
- * Due to its thickness, vinyl material may "bridge" over tight corners and edge profiles. Inside sharp corners will have a slight radius of no more than 3/16".
- * Matte, Satin and Embossed Foils may have no more than one occurrence of slight elevation or depression on the flat area of the door, while two occurrences are allowed in the machined area. Very distinctive characteristics will not be more than 1/16" in diameter.
- * High Gloss Foil may have no more than one occurrence of slight elevation or depression on the flat area of the door, while two occurrence are allowed in the machined area. Uneven reflection of light will not cover an area greater than 1/2" in diameter. Impressions that telegraph through the vinyl but do not blend into the surrounding plane are not acceptable. Depressions will be no more than 1/16" in diameter.
- * Slight vinyl distortion occurring when vinyl is wrapped around tight corners is not considered a defect. Non-edge wrapped stretch marks are allowed, one per 5" of the door's width and length.
- * RTF products are not warranted when used in areas where temperatures could exceed 160° F. Use at least 1" wood or laminate filler between all heat sources and your cabinets.
- * All RTF products will have edge treatment to ease sharp edge.

Warranty

- * All RTF foils are guaranteed against discoloration and deterioration for a period of three years.
- * Any door less than 26" wide and 48" high is guaranteed against warpage of no more than 1/8". Any door that exceeds either of these dimensions carries a warpage guarantee of no more than 1/4".
- * Unfinished doors up to 48" high and/or 26" wide carry one (1) year warranty against warpage of no more than 1/8". Doors over these dimensions carry a warranty against warpage of no more than 1/4".
- * All finishes meet the stringent requirement of the Kitchen Cabinet Manufacturers Association (KCMA).
- * Slight imperfections such as dimples or dust particles are unavoidable are considered acceptable.
- * All replacement claims are subject to our inspection.
- * Return of damaged parts is mandatory for inspection and replacement will not comense until then.
- * Any modification of part will void warranty.

Shipping/Delivery Notes

Hallmark Truck Delivery

Whenever possible Hallmark will arrange delivery by our own trucks. Please check with your sales representative to verify if you are in one of our delivery areas, if not your orders will be shipped freight or UPS.

UPS and Freight

Freight orders are shipped freight collect. Actual UPS charges are calculated by weight and added to the invoice at the time of shipment (\$5.00 is UPS minimum.) Please contact your sales representative for any special freight specifications. We package our product according to weight and fragility. Our packaging **exceeds** UPS standard. We do not, however, guarantee UPS shipments. We will assist you in the preparation of any necessary claims.

Rush Delivery & Last Minute Changes

Please identify any rush delivery needs and we will do our best to accommodate these needs. No changes can be made on rush orders once order is placed

Lead Times

- Prime and RTF completed in 7-14 working days
- Raw completed in 3-5 working days
- Painted High Gloss delivered in 10-17 working days

Payment

The payment terms are as follows:

- 50% due before production start. 50% due at time of pickup
- 0% down for those with approved credit and established account

Sorry, we do NOT accept credit cards.

Ordering Guidelines

General Information

Orders can be faxed to Dave's 24 hours a day at (757) 421-4252. Orders may also be phoned in, given to our sales representatives, delivered, or mailed. We always confirm orders. Our order desk is available at (757) 421-3283, Monday through Friday, 8:00 am - 4:00 pm EST. Due to delivery commitments, orders placed today will be on the shop floor by the following morning. **ALL** changes must be made on the same day the order is placed. Orders changed there after are charged for material and time. Rush orders are sent to the shop floor immediately. Any change made to rush order will require a charge for material and time.

Confirmation of FAX Orders

Please use our current order form and complete the heading to expedite the process.

- FAX orders - We will call you to verify receipt of your order and confirm ship date(s) within 4 hours.
- Avoid duplicate FAX's - If you do not receive a confirmation or a call back please call. If your FAX machine displays an error during transmission please do not re-send without calling our order representative. Let our order representative know that you are re-sending the FAX order.

Confirmation of Phone Orders for Clients without Fax Capabilities

Please listen carefully and check your order when we read it back to you. The **Read Back** is your confirmation of the order. Any corrections not made during the **Read Back** becomes your responsibility. Some helpful hints.

- Read your sizes slowly and clearly
- Mark off each size as you read it to our order representative
- Double check the heading information. We will repeat the heading to you. If an error is made in the heading, the entire order will be incorrect.*
- For ease of ordering use a Hallmark order form.

**We want to give you confidence that your order is taken correctly. If you have any doubt, please ask the order desk representative to verify the specific information in question.*

Confirmation of Orders Taken or Received by Our Employees

Upon the read back we will mail you a invoice copy of the agreement. Failure to response to the invoice copy constitutes consent. Rush orders will only be accepted via fax.

Door Millwork Nomenclature

Traditional Doors & Drawers

Panel Profiles

CL - Classic
 CO - Cove
 FA - Fancy
 RG - Regency
 RL - Regal
 SH - Shaker
 SL - Slab

Door Shapes

A2 - Double Arcadia
 AR - Arcadia
 CA - Cathedral
 C2 - Double Cathedral
 GO - Gothic
 HR - Half Round
 LA - Left Accent
 LH - Left Quarter
 LR - Left Arcadia
 RA - Right Accent
 RH - Right Quarter
 RR - Right Arcadia
 SQ - Square

Lite Doors

Lites

1L - 1 Lite
 4L - 4 Lite
 6L - 6 Lite
 8L - 8 Lite

Door Shapes

A2 - Double Arcadia
 AR - Arcadia
 CA - Cathedral
 C2 - Double Cathedral
 GO - Gothic
 HR - Half Round
 LA - Left Accent
 LH - Left Quarter
 LR - Left Arcadia
 RA - Right Accent
 RH - Right Quarter
 RR - Right Arcadia
 SQ - Square

Contemporary Doors/Drawers

BR - Bradford
 EZ - Elizabeth
 LE - Leslie
 PA - Palmer
 BS - Brussels
 HA - Harvard
 LX - Lexington
 WA - Warren

Contemporary Lite

BR - Bradford
 EZ - Elizabeth
 LE - Leslie
 PA - Palmer
 BS - Brussels
 HA - Harvard
 LX - Lexington

Special Profile Doors/Drawers

CM - County Manor
 GL - Glasgow
 KH - Knob Hill
 N1 - Nichols
 W1 - Winchester

Special Lite Door

CM - County Manor
 GL - Glasgow
 KH - Knob Hill
 N1 - Nichols
 W1 - Winchester

Edge Detail

HM - Hallmark Ogee
 MI - Milan
 SL - Softline 1/8
 QR - Quarter Round
 WO - Wide Ogee
 SQ - Square (PG only)

Finish Options

FW- M - Frosty White Matte
 FW- S - Frosty White Satin
 AW - Antique White (Satin Only)
 HGW - High Gloss White
 MAPLE - Natural Maple (Fusion Maple)
 LCHRY - Light Cherry
 MCHRY - Medium Cherry
 PRI - Primed
 HDF - RAW HDF
 949- M - Alpine White Matte
 949- S - Alpine White Satin

**We're
Limited
Only By
Your
Imagina-
tion.**